

Pressure Transmitter for Shipbuilding and Off-Shore Model ECO-1

WIKA Data Sheet PE 81.18



Applications

- Monitoring of diesel engines, gears, pumps, transmissions and filters
- Hydraulic and pneumatic control systems

Special Features

- Pressure ranges from 0 ... 1 bar to 0 ... 1000 bar
- Wiring with plug or flying lead
- Ingress protection IP 65 to IP 67
- Case and wetted parts of stainless steel
- Medium temperature -40 ... +100 °C / -40 ... +212 °F



Fig. Pressure transmitter ECO-1

Description

The principle features of these pressure transmitters are their sturdy and compact construction as well as their flexibility which make these instruments universally suitable for a variety of measuring tasks.

Wetted parts are made of stainless steel and are hermetically welded. Therefore there is no need for additional sealing material, which could possibly react with the pressure medium. The compact case is also made of stainless steel and normally provides IP 65 ingress protection.

Power supply of the pressure transmitters may be by means of non-stabilised DC of 10 ... 30 V providing the 2-wire output signal 4 ... 20 mA which is required by measuring standards.

Electrical connection of the pressure transmitter is available as L-connector in accordance with DIN 43 650 providing ingress protection IP 65 or as flying lead providing ingress protection IP 67.

Based on the technical data and the attractive price level, this pressure transmitter series qualified for applications where quantities of medium or large size are required and where reliability and efficiency play an important role.

Specifications

Model ECO-1

Pressure ranges	bar	1	1.6	2.5	4	6	10	16	25
Over pressure safety	bar	5	10	10	17	35	35	50	50
Burst pressure	bar	6	12	12	20.5	42	42	80	80
Pressure ranges	bar	40	60	100	160	250	400	600	1000
Over pressure safety	bar	80	120	200	320	500	800	1200	1500
Burst pressure	bar	200	300	500	800	1250	1300	1800	3000
{Absolute pressure: 0 ... 1 bar abs to 0 ... 16 bar abs}									
Materials									
■ Wetted parts									Stainless steel
■ Case									Stainless steel
■ Internal transmission fluid ¹⁾									Synthetic oil
1) Not for models with pressure ranges > 16 bar.									
Power supply UB	UB in VDC	10 < UB ≤ 30 (14 ... 30 with signal output 0 ... 10 V, 1 ... 6 V)							
Signal output and maximum ohmic load RA	RA in Ohm	4 ... 20 mA, wire RA ≤ (UB - 10 V) / 0.02 A							
Current limit	mA	32							
Response time (10 ... 90 %)	ms	≤ 5 (≤ 10 ms at medium temperatures < -30 °C for pressure ranges up to 16 bar)							
Insulation voltage	VDC	500 ²⁾							
2) NEC Class 02 power supply (low voltage and low current max. 100 VA even under fault conditions)									
Accuracy	% of span	≤ 0.5 (BFSL)							
	% of span	≤ 1.0 ³⁾							
3) Including non-linearity, hysteresis, zero point and full scale error (corresponds to error of measurement per IEC 61298-2)									
Adjusted in vertical mounting position with lower pressure connection									
Non-linearity	% of span	≤ 0.4 (BFSL) according to IEC 61298-2							
1-year stability	% of span	≤ 0.3 (at reference conditions)							
Permissible temperature of									
■ Medium ⁴⁾		-40 ... +100 °C				-40 ... +212 °F			
■ Ambience ⁴⁾		-30 ... +80 °C				-22 ... +176 °F			
■ Storage ⁴⁾		-30 ... +100 °C				-22 ... +212 °F			
4) Also complies with EN 50178, Tab. 7, Operation (C) 4K4H, Storage (D) 1K4, Transport (E) 2K3									
Compensated temp. range		0 ... +80 °C				+32 ... +176 °F			
Temperature coefficients within compensated temp range									
■ Mean TC of zero	% of span	≤ 0.4 / 10 K							
■ Mean TC of range	% of span	≤ 0.3 / 10 K							
CE-conformity									
■ Pressure equipment directive		97/23/EC							
■ EMC directive		89/336/EEC emission (class B) and immunity according to EN 61 326							
Approval German Lloyd GL		Environmental Category D, F							
ESD	kV	± 8	Contact discharge					IEC 1000-4-2	
Electromagnetic fields	V/m	10	80% AM; 1 kHz 0.01 ... 1000 MHz (300 ... 600 MHz increased error < 5 %)					IEC 1000-4-3	
Burst	kV	± 2	Coupling clamp					IEC 1000-4-4	
Conducted HF-disturbance	V	3	80% AM; 1 kHz 0.01 ... 100 MHz (up to 1MHz increased error < 2 %)					IEC 1000-4-6	
Surge	kV	± 0.5	Symmetrically } Asymmetrically } Symmetrically } Asymmetrically }					Ri = 42 Ohm Ri = 42 Ohm With surge protection only e. g. model MM-DS/xNFE(L) Dehn & Söhne Company or similar	
	kV	± 1							
	kV	± 1							
		± 2							
Conducted LF-disturbance	Veff.	3	0.05 ... 10 kHz					IEC 945	

Specifications

Model ECO-1

Wiring protection		
■ Overvoltage protection	VDC	36
■ Short-circuit proofness		Sig+ towards UB-
■ Reverse polarity protection		UB+ towards UB-
Weight	kg	Ca. 0.15

{ } Items in curved brackets are optional extras for additional price.

Dimensions in mm

Ingress Protection IP per IEC 60529. The ingress protection classes specified only apply while the pressure transmitter is connected with female connectors that provide the corresponding ingress protection.

Electrical connections

DIN 175301-803 A
L-connector (ship approval)
for conductor cross section up to max. 1.5 mm²,
conductor outer diameter 6 to 8 mm,
IP 65
Order code:
A4 and G (approvals)

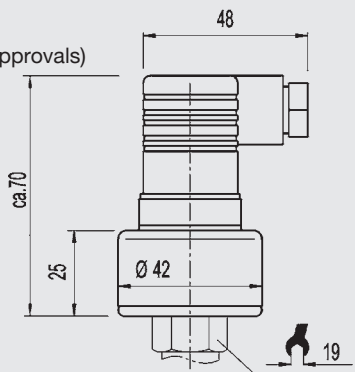

{Flying leads with 1.5 m of cable,
conductor cross section up to max. 0.5 mm²,
AWG 20 with end splices,
conductor outer diameter 6.8 mm,
IP 67
Order code: DL}

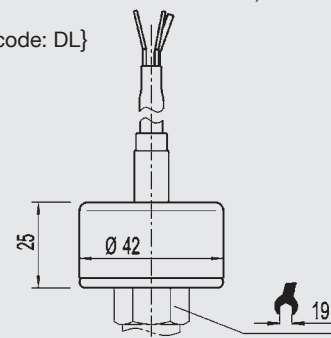

Pressure connections

G 1/4
EN 837
Order code: GB

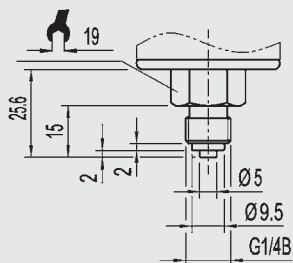

1/4 NPT
„Nominal size for US
standard tapered pipe
thread NPT“
Order code: NB

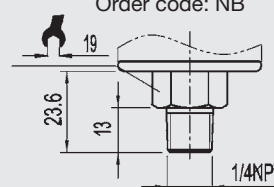

{ } Items in curved brackets are optional extras for additional price.

For installation and safety instructions see the operating instructions for this product.

For tapped holes and welding sockets please see Technical Information IN 00.14 for download at www.wika.de -Service

Wiring details

DIN 175301-803 A
L-Connector

2-wire

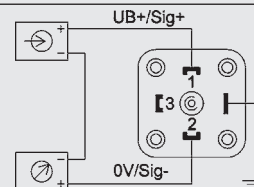

Flying leads

Legend:

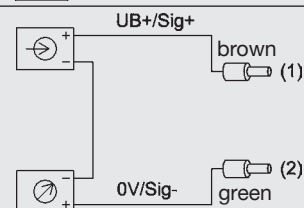
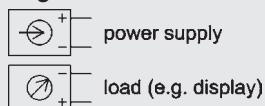

Further pressure transmitter from our OEM production



Fig. Pressure transmitter MH-2 with thinfilm technology for mobile hydraulic applications see data sheet PE 81.37

Further information

You can obtain further information (data sheets, instructions, etc.) via our internet address www.wika.de

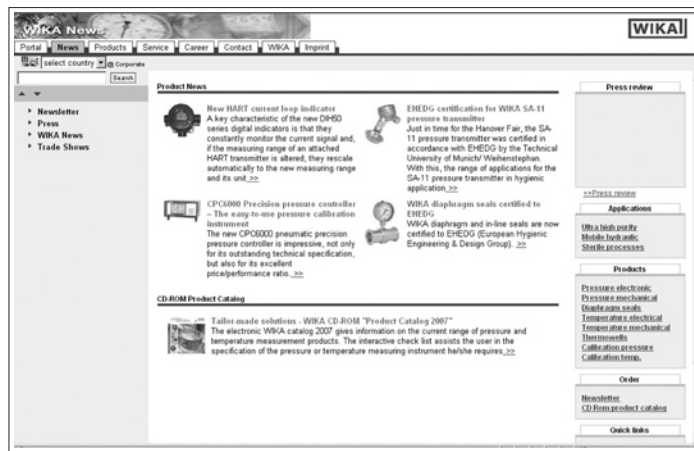

Specifications and dimensions given in this leaflet represent the state of engineering at the time of printing. Modifications may take place and materials specified may be replaced by others without prior notice.



WIKAL Alexander Wiegand GmbH & Co. KG
 Alexander-Wiegand-Straße 30
 63911 Klingenberg/Germany
 Tel. +49 / (0) 9372/132-0
 Fax +49 / (0) 9372/132-406
 E-mail info@wika.de
www.wika.de