

Analogue Temperature Transmitter Model T19.10, Configurable Ranges, Head Mounting Model T19.30, Configurable Ranges, Rail Mounting

WIKA Data Sheet TE 19.03



Applications

- Plant construction
- Power engineering
- Heating, ventilation, air-conditioning, refrigeration

Special Features

- Designs for Pt100 or thermocouples
- Configurable measuring ranges (soldered jumpers)
- Fault signal for sensor burnout and sensor short-circuit
- Large ambient temperature range
- Compact and inexpensive



Left: Analogue Temperature Transmitter Model T19.10
Right: Analogue Temperature Transmitter Model T19.30

Description

The analogue transmitters in the T19 series are provided with configurable ranges and are intended for use with both resistance thermometers and insulated thermocouples. Simply by setting the solder jumpers, one of the several available measuring ranges can be selected. Therefore, these transmitters are especially suitable for applications where frequently changing requirements have to be taken into account.

The temperature transmitter converts either temperature-dependent changes in resistance, in the case of resistance thermometers, or temperature-dependent changes in voltage, in the case of insulated thermocouples, into a 4 ... 20 mA loop signal. This guarantees the simple and reliable transmission of the measured temperature values.

Accuracy, sensor monitoring and the permissible ambient conditions are matched to the requirements of industrial applications.

For direct mounting into the temperature probe, the instrument case is configured as a head-mounted transmitter and can be easily mounted into any DIN Form B connection head.

The rail mounting case fits to any standard rail per DIN EN 50 022 - 35.

Specifications		Model T19.10 and T19.30						
		1P01	1P02	1P03	3J04	3K04	3S04	3T04
Input		1 x Pt100 per IEC 60 584 ($\alpha = 0.00385$) *			Thermocouple per IEC 584 **			
		2 or 3 wire			1 x Type J (Fe-CuNi)	1 x Type K (NiCr-Ni)	1 x Type S (PtRh-Pt)	1 x Type T (Cu-CuNi)
■ Not configured		not factory configured / the measuring range can be configured via solder jumpers, within the limits specified below			not factory configured / the measuring range can be configured via solder jumpers, within the limits specified below			
■ Standard ¹⁾	°C	-50 ... +50	-50 ... +200	-30 ... +30	0 ... 350	0 ... 300	0 ... 1500	-100 ... +200
	°C	0 ... 50	0 ... 200	-30 ... +50	0 ... 550	0 ... 600	-	-100 ... +300
	°C	0 ... 100	0 ... 250	0 ... 60	0 ... 700	0 ... 1200	-	0 ... 400
	°C	0 ... 120	0 ... 300	0 ... 80	-	-	-	-
	°C	0 ... 150	0 ... 350	0 ... 100	-	-	-	-
	°C	0 ... 200	0 ... 400	0 ... 120	-	-	-	-
■ Special measuring ranges		factory-configured, permanent, changing the measuring range configuration is no longer possible			factory-configured, permanent, changing the measuring range configuration is no longer possible			
Adjustment range Zero point	°C	approx. ± 10	approx. ± 25	approx. ± 30	approx. ± 40			
Adjustment range Span	%	approx. 10			approx. 10			
Sensor measuring current		approx. 0.8 mA			-			
Max. output resistance		30 Ω per wire, 3-wire symmetric			250 Ω per wire			
Cold junction compensation		-			yes			
Analogue output		4 ... 20 mA, 2-wire design			4 ... 20 mA, 2-wire design			
Linearisation		proportional to temperature per IEC 60 751/ DIN 43 760			proportional to voltage			
Output limits								
Sensor burnout	mA	down scale, < 3 ²⁾			up scale, > 23.5			
Sensor short circuit	mA	down scale, < 3 ³⁾			-			
Rise time t_{90}	s	< 0.01			< 0.02			
Switch-on time (time to first measured value)	s	< 0.1			< 0.1			
Measuring rate		Permanent (analogue system)			Permanent (analogue system)			
Power supply U_B ⁴⁾		DC 10 ... 30 V from 4 ... 20 mA-loop			DC 10 ... 30 V from 4 ... 20 mA-loop			
Load R_A		$R_A \leq (U_B - 10 \text{ V}) / 0.02 \text{ A}$ with R_A in Ω and U_B in V			$R_A \leq (U_B - 10 \text{ V}) / 0.02 \text{ A}$ with R_A in Ω and U_B in V			
Measuring deviation per DIN EN 60 770, at 23 °C ± 5 K	%	± 0.5 ⁵⁾			± 0.5 ⁵⁾			
Load effect	%/100	± 0.05			± 0.05			
Power supply effect	%/V	± 0.025			± 0.025			
Warm-up time		5 minutes to reach data sheet specifications			5 minutes to reach data sheet specifications			
Linearity error	%	± 0.1 ⁶⁾			-			
Amplification error	%	-			± 0.1			
Error effect of cold junction compensation		-			at $T_{amb} -20 \dots +60 \text{ °C} \pm 1 \text{ K}$ at $T_{amb} -40 \dots +85 \text{ °C} \pm 2 \text{ K}$			
Temperature coefficient T_K of -40 ... 85 °C		ZP: ± 0.1 %/10 K or ± 0.2 K/10 K ⁷⁾ Span: ± 0.2 K/10 K			ZP: ± 0.1 %/10 K or ± 0.25 μV/10 K ⁷⁾ Span: ± 0.2 K/10 K			
Effect of the supply lead resistances		3-wire: ± 0.2 K / 10 Ω 2-wire: resistance of the supply lead			± 0.2 K / 10 Ω			
Electromagnetic compatibility (EMV)		CE-Conformity per DIN EN 61 326-1			CE-Conformity per DIN EN 61 326-1			
Galvanic isolation ⁸⁾ between the sensor and output side (4 ... 20 mA)		No			No			

* Pt1000 and special measuring ranges on request.

** Further thermocouple types and special measuring ranges on request.

1) Further units e.g. °F and K are possible.

2) Up scale, in the event only lead no. 1 open-circuit.

3) Temperature value, in the event of a short between leads no. 2 and no. 3 (operation of Pt100 in 2-wire configuration).

4) Input power supply protected from reverse polarity.

5) With factory configured measuring range.

6) ± 0.15 % with measuring range: 0 ... 50 °C, 0 ... 300 °C, 0 ... 350 °C

7) Whichever is greater.

8) A non-isolated thermocouple can cause a ground loop if the T19 does not have an ungrounded connection, which can, in turn, lead to the T19 malfunctioning.

Load diagram

The permissible load is dependent upon the loop power supply voltage.

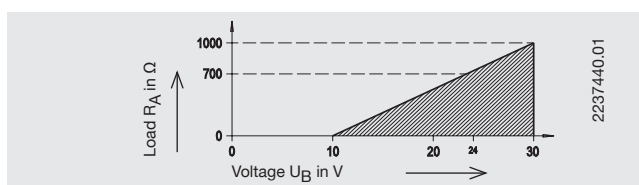

Case

Model	Material	Weight	Ingress protection Case (terminal connection)	Terminal connection (captive screws)
T19.10	plastic, PA, glass-fibre reinforced	approx. 0.03 kg	IP00 (IP40)	0.14 ... 1.5 mm ²
T19.30	polyamide, glass-fibre reinforced	0.05 kg	IP10 (IP40)	0.5 ... 1.5 mm ²

Ambient conditions

Model	Climate class per DIN IEC 60 068-2-30	Ambient / storage temperature	Vibration per DIN IEC 60 068-2-6	Shock per DIN IEC 60 068-2-27
T19.10	Cx (-40 ... +85 °C, 5 % to 95 % relative humidity)	-40 ... +85 °C	10 ... 2000 Hz; 5g	10 g
T19.30	Bx (-20 ... +70 °C, 5 % to 95 % relative humidity)	-20 ... +70 °C	10 ... 2000 Hz; 5g	10 g

Transmitter Model T19.10, head mounting version Dimensions in mm

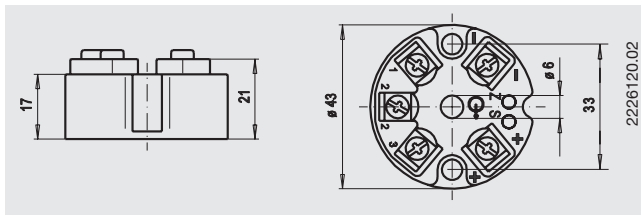

Transmitter Model T19.30, rail mounting version

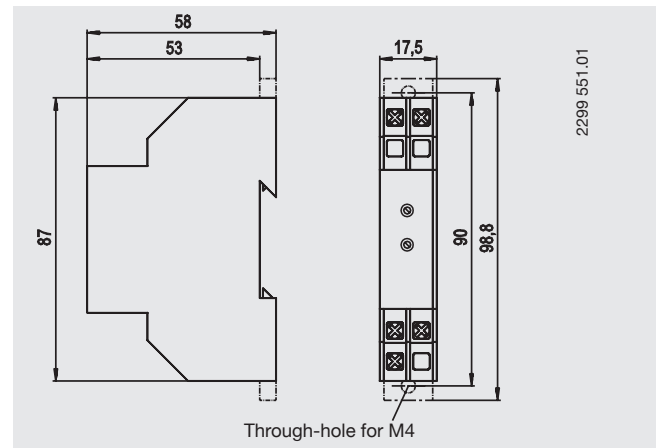

Designation of terminal connectors

Input Pt100 / Model T19.10.1P0x

Resistance thermometer /
resistance sensor

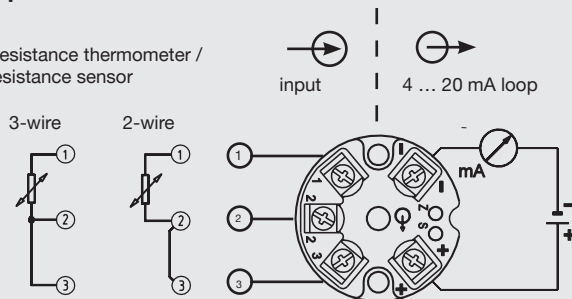

Input Pt100 / Model T19.30.1P0x

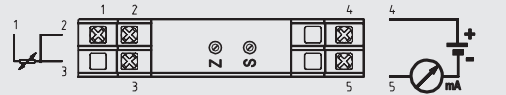

Input thermocouple / Model T19.10.3x04

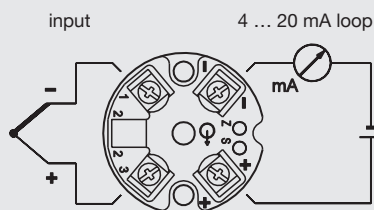

Input thermocouple / Model T19.30.3x04

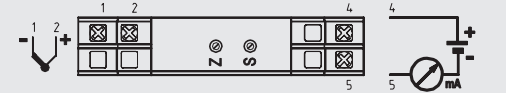

Accessories for Model T19.10 temperature transmitter, head mounting version (please order separately) Order No.

Adapter, plastic/stainless steel, dimensions: 60 x 20 x 41.6 mm Suitable for TS 35 per DIN EN 60 715 (DIN EN 50 022 or TS 32 per DIN EN 50 036)	3593789
Adapter, tuned steel, dimensions: 49 x 8 x 14 mm Suitable for TS 35 per DIN EN 60 715 (DIN EN 50 022)	3619851
Fieldcase, plastic (ABS), ingress protection IP 65, dimensions: 82 x 80 x 55 mm (W x L x H) For head mounting of transmitter, permissible ambient temperature range: -40 °C ... +80 °C, with two M16 x 1.5 cable glands	3301732

Ordering information

Field No.	Code	Features
		Model
1	T19.10	T19.10, head mounting
	T19.30	T19.30, rail mounting

	Code	Features
2	1P	Pt100
3	1	measuring range up to 200 °C
	2	measuring range above 200 °C
	3	measuring range HVAC
	9	special measuring range
	NK	not configured
	EA	-50 ... +50 °C
	1A	0 ... 50 °C
	1E	0 ... 100 °C
	1F	0 ... 120 °C
	1H	0 ... 150 °C
4	1L	0 ... 200 °C
	NK	not configured
	EL	-50 ... +200 °C
	1L	0 ... 200 °C
	1M	0 ... 250 °C
	1N	0 ... 300 °C
	1P	0 ... 350 °C
	1Q	0 ... 400 °C
	NK	not configured
	CA	-50 ... +30 °C
	CB	-30 ... +50 °C
	1C	0 ... 60 °C
	1D	0 ... 80 °C
	1E	0 ... 100 °C
	1F	0 ... 120 °C

	Code	Features
2	3J	Type J (Fe-CuNi)
3	4	measuring range type J
	9	special measuring range
	NK	not configured
	1P	0 ... 350 °C
	1T	0 ... 550 °C
4	1W	0 ... 700 °C
	NK	not configured
	1N	0 ... 300 °C
	1U	0 ... 600 °C
	12	0 ... 1200 °C

	Code	Features
2	3S	Type S (PtRh-Pt)
3	4	measuring range type S
	9	special measuring range
	NK	not configured
	15	0 ... 1500 °C
4		
	NK	not configured
	KA	-100 ... +200 °C
	KB	-100 ... +300 °C
	1Q	0 ... 400 °C

	Code	Features
5	YES	NO
	T	Z
		additional text

Please state as clearly understandable text!

Order code

1	2	3	4	5
<input style="width: 80%;" type="text"/>	- <input style="width: 80%;" type="text"/>	0 - <input style="width: 80%;" type="text"/>	- <input style="width: 80%;" type="text"/>	- <input style="width: 80%;" type="text"/>

Additional text: _____

Example.: T19.10-3K0-41N-Z
 T19.10 head mounting version
 Thermocouple type K (NiCr-Ni)
 Measuring range type K: 0 ... 300 °C
 without additional text

Specifications and dimensions given in this leaflet represent the state of engineering at the time of printing. Modifications may take place and materials specified may be replaced by others without prior notice.



WIKAL Alexander Wiegand GmbH & Co. KG
 Alexander-Wiegand-Straße 30
 63911 Klingenberg/Germany
 Tel. (+49) 9372/132-0
 Fax (+49) 9372/132-406
 E-mail info@wika.de
 www.wika.de