

Digital Temperature Transmitter

with HART® - Protocol, Rail Mounting

Electrical Temperature Measurement



Applications

- Process industry
- Machinery, plant construction

Special Features

- Functional safety (SIL 2)
- Monitoring of sensor lead resistance acc. NAMUR NE 89
- Signalling acc. NAMUR NE 43 individually configurable signalling for possible errors of the sensor system
- Configuration and write protection via password
- Configurable via
 - User friendly WIKA Configuration Software
 - HART® Communicator HC 275 / FC 375
 - Asset Management Systems



Description

The digital temperature transmitter T32 range is designed for universal use in the process industry.

Comprehensive individual configuration possibilities like, for example, type of sensor, measuring range and error signalling, high accuracy, galvanic isolation and excellent EMI protection characterize these transmitters.

The rail mounting case fits to any standard rail per DIN EN 50 022 - 35.

During configuration any one of 15 types of sensors can be selected. Measured temperatures are from -270 °C up to 1820 °C.

Configuration can be done by means of a HART® Communicator model HC 275 / FC 375, with FSK modem (e.g. VIATOR®) via the RS 232-C of a standard DOS PC, or with the HART functionality of a Asset Management System or DCS system.

The following sensors can be connected:

- RTDs per DIN EN 60 751, JIS C 1606, DIN 43 760 in 2, 3 and 4 wire connection, the connection-system used is configurable and ensures an optimal lead wire compensation
- thermocouples per DIN EN 60 584 resp. DIN 43 710 Cold junction compensation (CJC) is built-in, the use of an external CJC is selectable via configuration.
- resistance-sensors up to 5000 Ω in 2, 3 and 4 wire connection, configurable compensation of the connection cable
- mV-sensors up to 1200 mV

The transmitters are delivered with a basic configuration (see ordering information). Alternatively, upon request, transmitters can be delivered with a customized configuration within the given limits.

Also available as head mounting version: model T32.10, see data sheet TE 32.01.

Specifications

Model T32.30

Input	configurable: type of sensor and measuring range	max. measuring range	minimum measuring span
RTDs	Pt100 ($\alpha=0,00385$) DIN EN 60751	-200 ... + 850 °C ¹⁾	10 K or 3,8 Ω , whichever is greater
	Pt (x) x configurable btw. 10 ... 1000 e.g. for Pt10, Pt50, Pt500, Pt1000 etc.		
	JPt100 ($\alpha=0,003916$) JIS C 1606 (1989)	-200 ... + 500 °C	
	Ni 100 DIN 43760 (1987-09)	-60 ... + 250 °C	
thermocouples	type T, Cu-CuNi DIN EN 60584	-270 ... + 400 °C	50 K or 2 mV, whichever is greater
	type E, NiCr-CuNi DIN EN 60584	-270 ... + 1000 °C	
	type J, Fe-CuNi DIN EN 60584	-210 ... + 1200 °C	
	type L, Fe-CuNi DIN 43710 (1985-12)	-200 ... + 900 °C	
	type K, NiCr-Ni DIN EN 60584	-270 ... + 1372 °C	
	type N, NiCrSi-NiSi DIN EN 60584	-270 ... + 1300 °C	
	type U, Cu-CuNi DIN 43710 (1985-12)	-200 ... + 600 °C	
	type R, PtRh-Pt DIN EN 60584	-50 ... + 1768 °C	
	type S, PtRh-Pt DIN EN 60584	-50 ... + 1768 °C	
	type B, PtRh-PtRh DIN EN 60584	0 ... + 1820 °C	
resistance sensor		0...700 Ω / 0 ... 5000 Ω	4 Ω up to 32 Ω
mV-sensor		-400 ... + 1200 mV	4 mV up to 32 mV
signalling of sensor error		configurable (up scale, down scale, customer specific)	
RTDs / resistance sensor			
measuring deviation per DIN EN 60770, 23 °C \pm 5 K			
RTDs ⁴⁾	MV \leq 200 °C	\pm 0.08 K	
	MV > 200 °C	\pm (0.08 K + 0,01 % (MW - 200 K))	
resistance-sensor ⁴⁾		\pm 0.03 Ω or 0.01 % MW, whichever is greater	
temperature coefficient T_C ²⁾	RTDs	\pm (0.05 K + 0.015 % MW) / 10 K_{Ta}	
	resistance-sensor	\pm (0.01 Ω + 0,01 % MW) / 10 K_{Ta}	
sensor current		approx. 0,2 mA	
lead wire connection		configurable: 2 wire, 3 wire, 4 wire	
connection leads	effect	\pm 0.02 Ω / 10 Ω	
	max. permissible resistance	30 each wire, 3 wire symmetric	
monitoring NAMUR NE 89 (Pt 100, 4 wire), i.e. sensor burn out is signalled, if:		$R_{L_2} + R_{L_3} > 128 \Omega \pm 0.1 \Omega$ with hysteresis 12 $\Omega \pm 0.1 \Omega$	
		$R_{L_1} + R_{L_4} + R_{Pt100} > 14,5 \text{ k}\Omega \pm 30 \%$ with hysteresis 750 $\Omega \pm 20 \%$	
thermocouples / mV-sensor			
measuring deviation per DIN EN 60770, 23 °C \pm 5 K			
type T, L, U	-150 °C < MV \leq 0 °C	\pm (0.25 K + 0.15 % MV)	
	MV > 0 °C	\pm (0.25 K + 0.015 % MV)	
E, J, K, N	-150 °C < MV \leq 0 °C	\pm (0.4 K + 0.2 % MV)	
	MV > 0 °C	\pm (0.4 K + 0.03 % MV)	
R, S	50 °C < MV \leq 400 °C	\pm (1.2 K + 0.1 % MV - 400 K)	
	400 °C < MV \leq 1600 °C	\pm (1.2 K + 0.015 % MV - 400 K)	
B	400 °C < MV \leq 1000 °C	\pm (1.3 K + 0.25 % MV - 1000 K)	
	MV > 1000 °C	\pm 1.3 K	
mV-sensor		\pm (10 μ V K + 0.03 % MV)	
temperature coefficient T_C ²⁾	type T, L, U	MV > -150 °C	\pm (0.1 K + 0.02 % MV) / 10 K_{Ta}
		MV > -150 °C	\pm (0.1 K + 0.035 % MV) / 10 K_{Ta}
	R, S	50 °C < MV \leq 1600 °C	\pm (0.3 K + 0.025 % MV - 400 K) / 10 K_{Ta}
		400 °C < MV \leq 1000 °C	\pm (0.4 K + 0.02 % MV - 1000 K) / 10 K_{Ta}
	mV-sensor	MV > 1000 °C	\pm (0.4 K + 0.02 % MV - 1000 K) / 10 K_{Ta}
additional error of cold function compensation ³⁾ at 23°C \pm 5 K		\pm 0.8 K	
temperature coefficient T_C ²⁾ of cold function compensation ³⁾		\pm 0.1 K / 10 K_{Ta}	
connection leads	effect	\pm 0.1 μ V / 10 Ω	
	max. permissible resistance	250 Ω each wire	
	monitoring NAMUR NE 89, i.e. error burn out is signalled, if:	$R_{L_1} + R_{L_4} + R_{thermocouple} > 14.5 \text{ k}\Omega \pm 30 \%$ with hysteresis 750 $\Omega \pm 20 \%$	

MV measuring value (temperature measuring values in °C)

R_{Lx} lead resistance at terminal X

T_a ambient temperature

T_C temperature coefficient

1) extended up to 1000 °C

2) between the standard range of ambient temperature $-20 \text{ °C} \leq T_a \leq +70 \text{ °C}$

3) only with thermocouple

4) Additional measuring deviation with 3 wire connection: 50 m Ω (approx. 0.13 K with Pt100) with adjusted supply lead resistances.

Ex-protection per Directive 94/9/EG energy limited resp. non sparking equipment per EN 50 021	Type Examination Certificate DMT 99 E 088 X
model T32.30.009	II 3G EEx nL/nA IIC T4/T5/T6
permissible ambient temperature	-20 °C ... +70 °C with T4 -20 °C ... +70 °C with T5 -20 °C ... +60 °C with T6
maximum values for the connection of the current loop circuit (connections + and -)	$U_i = DC 40V$ $C_i = 7.8 nF$ $L_i = 100 \mu H$
maximum values for the connection of the sensor circuit (connections 1 up to 4)	$U_o = DC 5.5 V$ $I_o = 0.21 mA$ $C_o = 1000 \mu F$ $L_o = 1000 mH$
Electromagnetic compatibility (EMC)	per EMV Directive 89/336/EWG EN 61326:1997 / A1:1998 and additional NAMUR NE 21 (May 93)
Ambient conditions	
ambient and storage temperature	-20 ... +70 °C
climat class	Bx (-20 ... +70 °C, 5 % up to 95 % relative humidity) DIN EN 60 654-1
maximum permissible humidity	90 % relative humidity (DIN IEC 68-2-30 Var. 2)
vibration	10 ... 2000 Hz 5g DIN IEC 68-2-6
shock	DIN IEC 68-2-27 $g_N = 30$
salt fog	DIN IEC 68-2-11
Special features	
communication	HART - protokol Rev. 5 inclusive burst mode, Multidrop
<p>All T32-parameter are configurable with following possibilities:</p> <ul style="list-style-type: none"> - user friendly WIKA Configuration Software, free of charge Download possible via www.wika.de - HART Communicator HC 275 / FC 375: T32 Device Description IS integrated resp. upgradable with old versions - Asset Management Systems <p>AMS: completely integrated resp. upgradable with old versions Simatic PDM: completely integrated from Version 5.1, upgradable with version 5.0.2 Smart Vision: upgradable by DTM per FDT 1.2 standard from SV version 4 via T32 DTM with all supporting applications with FDT 1.2 interface, such as PACTware (siehe Accessories page 6 DTM)</p> <p>The Configuration Set (see accessory) can be used for the direct communication with the serial interface of a PC</p> <p>Note: parameters, which are defined by a universally HART command (e.g. the measuring range) can be processed with all HART configuration tools in principle.</p> <p>The T32.30 has a direct connection for our FSK-modem (see accessories: configuration set).</p>	
isolation voltage (input versus analogue output)	AC 1500 V, 60 s
warm-up time	approx. 5 Min. ¹⁾
power consumption with $U_B 24 V$	max. 540 mW
temperature units	configurable: K, °C, °F, °R
configuration and kalibration data	permanently stored in EEPROM
testing current for monitor sensor	nom. 1 μA during testing cycle, otherwise 0 μA
self-monitoring	automatic execution of an initial test after connection to power supply, thereafter monitoring due to internal malfunction
Case	rail mounting design
material	plastic
ingress protection case	IP 40 IEC 529/ EN 60 529
terminal protections	IP 20 IEC 529/ EN 60 529
cross section of terminal protections	max. 2,5 mm ²
weight	approx. 200 g
dimensions	see drawings

1) Time, after turn on, until the instrument will function within specified repeatability.

Load diagram

The permissible load is dependant upon the loop power supply voltage.

load R_A in Ω

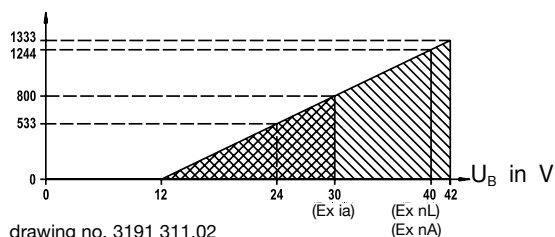

drawing no. 3191 311.02

Dimensions in mm

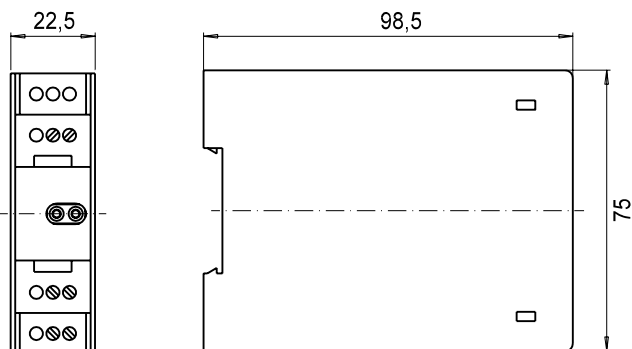

3191 303.01

Designations of terminal connectors

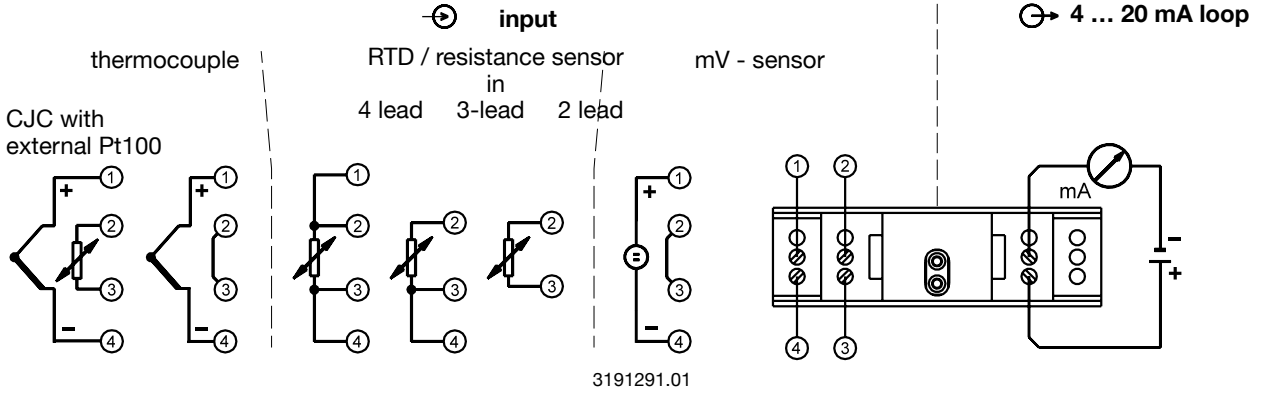

Accessory (Order No. see last page)

Field Communicator FC375



Meriam Field Communicator MFC4100-1



FSK-modem model 010031 with USB interface



Wiring scheme

Following must be observed, particularly with applications in hazardous area:

- The wiring scheme
- The total of all output values of all simultaneously connectd instruments (Power supply, FSK-Modem, HART® Communicator) must not exceed the permissible maximum values of the T32.

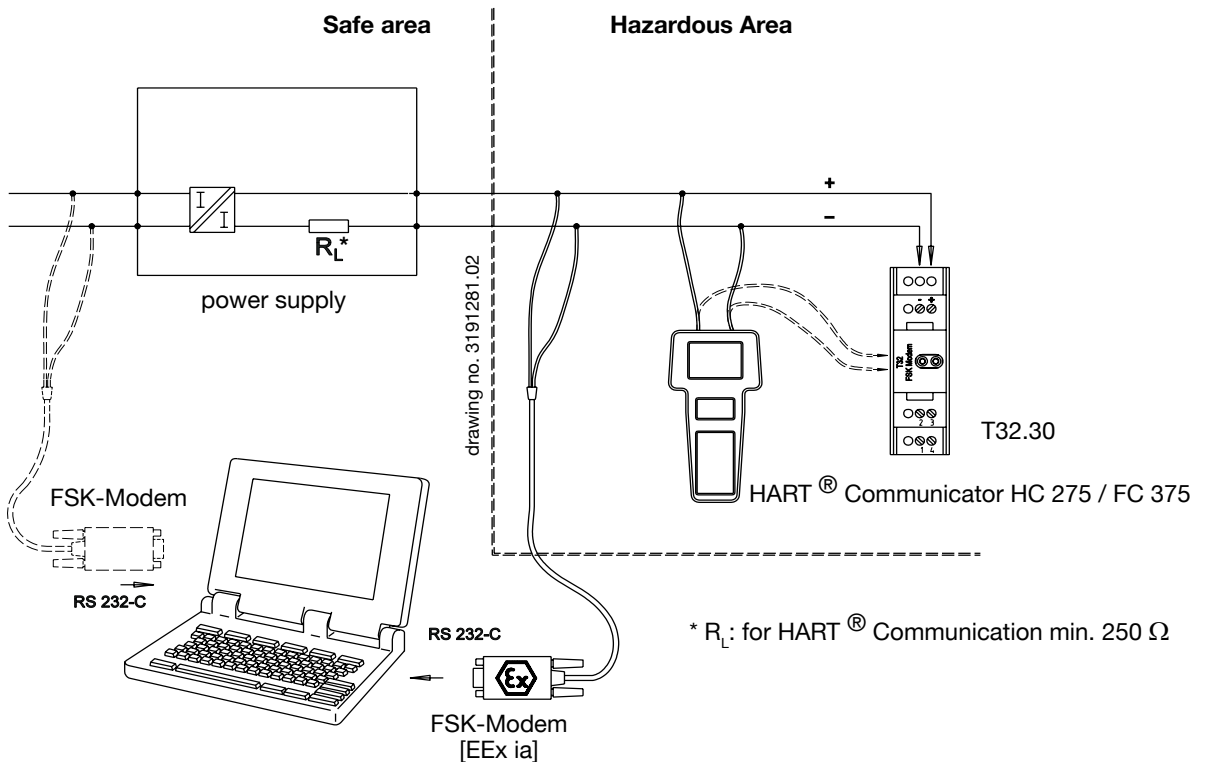

Ordering informationen for temperature transmitter Model T32.30

Field No.	Code	Features
Model		
1	T32.30	T32.30, rail mounting
Explosion protection		
	0	without
	2	II 1G EEx ia IIC T4/T5/T6 to directive 94/9/EG (ATEX)
	6	CSA Class I, Division 1, Group A, B, C and D
2	9	II 3G EEx nL/nA IIC T4/T5/T6
Measuring range		
	GK	basic configuration 1)
3	KK	customer's specification 2) <i>please state as additional text</i>
Ambient temperature		
4	R	Standard -20 °C ... +70 °C

Additional order info			
YES	NO		
T	Z	additional text	<i>Please state as clearly understandable text!</i>

Order code:

1	2	3	4	5
T32.30	- 00	□	R	□

Additional text:

Accessory <i>(please order separately)</i>	Order No.
Konfiguration Software T32 on 3.5" Disk 3)	3633374
FSK modem model 010031 with USB interface, particularly for use with modern notebooks	11025166
FSK modem model 010001 with RS232 interface	7957522
FSK modem model 010005 with RS232 interface and explosion protection according to ATEX	2442791
FIELD COMMUNICATOR FC375 englisch for HART, ATEX II 2G (1 GD) EEX IA IIC T4, FM CLASS I, DIVISION1, GROUPS A,B,C AND D T4, CSA EX IA IIC	2297486
NiMH Accu, with power supply 90-240 VAC, without EASY UPGRADE OPTION	
DTM Collection, incl. PACTware 3) includes DTMs for WIKA field instruments	12513636

- 1) Input signal: Pt100 in 3 wire connection, Measuring range: 0 ... 150 °C,
Output signal: 4 ... 20 mA, Output limits: NAMUR (lower limit: 3.8 mA upper limit: 20.5 mA),
Signalling of sensor error: NAMUR down scale (3.5 mA), Damping: off, Write protection: not activ
- 2) Please pay attention to the limits of measuring ranges on page 2.
- 3) Free of charge download from the WIKA Homepage www.wika.de

Die beschriebenen Geräte entsprechen in ihren Konstruktionen, Maßen und Werkstoffen dem derzeitigen Stand der Technik. Änderungen und den Austausch von Werkstoffen behalten wir uns vor.



WIKAL Alexander Wiegand GmbH & Co. KG
 Alexander-Wiegand-Straße · 63911 Klingenberg
 Tel.: (0 93 72) 132 - 0 · Fax: (0 93 72) 132 - 406
<http://www.wika.de> · E-mail: info@wika.de