

Digital Temperature Transmitters Model T12.10, Universally Programmable, Head Mounting

WIKA Data Sheet TE 12.01



Applications

- Machinery, plant construction
- Process industry

Special Features

- Universal configuration via Windows-PC, simulation of the sensor not necessary
- Isolation voltage 1500 VAC between sensor and current loop
- Signalling configurable for sensor burnout and sensor short circuiting
- 100 % Rh protection, moisture condensation permissible



Digital Temperature Transmitter Model T12.10

Description

These temperature transmitters are designed for universal industrial use. They are characterised by a high accuracy, galvanic isolation and EMI protection.

In addition to a wide variety of standard sensor types (e.g. sensors to DIN EN 60 751, JIS C1606, DIN 43760, DIN EN 60 584 or DIN 43 710), custom sensors can also be configured by entering the relevant value pairs.

The sensor connection arrangement is configurable, thus ensuring optimal lead wire compensation. Cold junction compensation for thermocouples is built-in, while external cold junction compensation can also be selected.

The configurable error signalling (e.g. sensor burnout, hardware errors, sensor over/under-range) ensures a high degree of monitoring flexibility.

Configuration changes can be quickly and easily transmitted to the T12 using the WIKAI_T12 configuration software (free download at www.wika.de) and the communication interface (programming unit), which is available as an accessory. Its two-way communication enables the measured values to be displayed on a PC/notebook.

The programming unit provides voltage to the T12 transmitter, so that no additional supply is required to configure the T12.

The dimensions of the head-mounting transmitters are suited to DIN Form B connection heads with an extended mounting space, e.g. WIKAI model BSS.

The rail mounting transmitters are suitable for all standard rails in accordance with DIN EN 50 022-35.

These transmitters are delivered either with a standard configuration or to customers' specification within the configuration limits possible.

Specifications

Model T12.10

Input	Type of sensor	Measuring range	Standard	Minimum measuring span ¹⁾
configurable RTDs	Pt100 ($\alpha = 0.00385$)	-200 °C ... +850 °C	DIN EN 60 751	25 K
	JPt100 ($\alpha = 0.003916$)	-200 °C ... +500 °C	JIS C 1606 (1989)	25 K
Thermocouples	Ni100	-60 °C ... +250 °C	DIN 43 760 (1987-09)	25 K
	type T, Cu-CuNi	-200 °C ... +400 °C	DIN EN 60 584	50 K
	type E, NiCr-CuNi	-100 °C ... +1000 °C	DIN EN 60 584	50 K
	type J, Fe-CuNi	-100 °C ... +1200 °C	DIN EN 60 584	50 K
	type L, Fe-CuNi	-100 °C ... +900 °C	DIN 43 710 (1985-12)	50 K
	type K, NiCr-Ni	-180 °C ... +1372 °C	DIN EN 60 584	50 K
	type N, NiCrSi-NiSi	-180 °C ... +1300 °C	DIN EN 60 584	100 K
	type U, Cu-CuNi	-200 °C ... +600 °C	DIN 43 710 (1985-12)	75 K
	type R, PtRh-Pt	-50 °C ... +1760 °C	DIN EN 60 584	200 K
	type S, PtRh-Pt	-50 °C ... +1760 °C	DIN EN 60 584	200 K
	type B, PtRh-PtR	0 °C ... +1820 °C ²⁾	DIN EN 60 584	200 K
	type W3, W3Re/W25Re	0 °C ... +2300 °C	ASTM E988	200 K
type W5, W5Re/W26Re	0 °C ... +2300 °C	ASTM E988	200 K	
Resistance sensor		0 ... 5000 Ω		30 Ω
mV - sensor		-10 ... +800 mV		5 mV
RTDs / resistance sensor				
Measuring deviation per DIN EN 60 770, 23 °C \pm 5 K				
	RTDs	$\pm 0.2 \text{ K or } ^3) \pm (0.025 \% \text{ FS} + 0.1) \text{ K}$		
	Resistance sensor	$\pm 0.07 \Omega \text{ or } ^3) \pm 0.03 \% \text{ FS in } \Omega$		
Sensor current		approx. 0.2 mA		
Temperature coefficient T_C	RTDs	$\pm (0.025 \% \text{ FS} + 0.09) \text{ K} / 10 \text{ K } T_{amb}$		
	Resistance sensor	$\pm (0.025 \% \text{ FS} + 0.01) \Omega / 10 \text{ K } T_{amb}$		
Lead wire connection		configurable: 2 wire, 3 wire, 4 wire		
Connection leads	Effect	$\pm 0.02 \Omega / 10 \Omega$		
	max. permissible resistance	30 Ω , 3 wire symmetric		
Signalling of sensor error		configurable		
Thermocouples				
Measuring deviation ⁴⁾ per DIN EN 60 770, 23 °C \pm 5 K				
Cold junction compensation				
Temperature coefficient T_C	type T, E, J, L, K, N, U	$\pm (0.05 \% \text{ FS} + 0.1) \text{ K} / 10 \text{ K } T_U \text{ or } ^3) \pm 0.5 \text{ K} / 10 \text{ K } T_{amb}$		
	type R, S, B, W3, W5	$\pm 2 \text{ K} / 10 \text{ K } T_{amb}$		
Connection leads	Effect	$\pm 0.5 \mu\text{V} / 10 \Omega$		
	max. permissible resistance	250 Ω		
Signalling of sensor error		configurable		
mV - sensor				
Measuring deviation per DIN EN 60 770, 23 °C \pm 5 K				
Temperature coefficient T_C				
Connection leads	Effect	$\pm 0.5 \mu\text{V} / 10 \Omega$		
	max. permissible resistance	250 Ω		
Analogue output for measuring range				
configurable: 4 ... 20 mA or 20 ... 4 mA, 2 wire design				
with type of sensor RTDs linear to temperature per DIN EN 60 751 / JIS C 1606 / DIN 43760 : 1987-09				
with type of sensor thermocouples linear to temperature per DIN EN 60 584 / DIN 43 710 : 1985-12 / ASTM E988				
by simulation mode independent from input signal, simulation value configurable from 3.5 mA up to 23 mA				
Output limits configurable				
Application specification				
NAMUR NE 43				
not active				
lower limit: 3.8 mA upper limit: 20.5 mA				
lower limit: 3.6 mA upper limit: 23 mA				
Load R_A	$R_A \leq (U_B - 9V) / 0.023 \text{ A}$ with R_A in Ω and U_B in V			
Load effect	$\pm 0.01 \% \text{ of measuring span} / 100 \Omega$			
Measuring deviation per DIN IEC 770, 23 °C \pm 5 K	$\pm 0.05 \% \text{ of measuring span}$			
Temperature coefficient T_C	$\pm 0.1 \% \text{ of measuring span} / 10 \text{ K } T_U$			
Damping	configurable: minimum 0.5 s, 1 s up to 60 s			
Measured value update	approx. 2 / s			
Power supply effect	$\pm 0.005 \% \text{ of measuring span} / \text{V}$			
Total measuring deviation				
sum of input + output per DIN EN 60 770, 23 °C \pm 5 K				
Signalling at analogue output				
with sensor error and internal malfunction				
NAMUR NE 43	up scale	< 3.6 mA		
	down scale	> 21.0 mA		
substitute value	configurable from 3.5 mA up to 23.0 mA			

- 1) Lower limit of range maximum 50 % of upper limit of range
- 2) Technical data valid only for configurated measuring range ≥ 400 °C
- 3) Whichever is greater
- 4) Valid only for configured lower limit of range ≥ -150 °C

- FS Full scale value of configured measuring range
 R_A Load
 T_C Temperature coefficient
 T_{amb} Ambient temperature
 U_B Loop power supply voltage, see power supply

Specifications, continued
Model T12.10

Power supply U_B	
Model T12.10.000 (without Ex-protection)	DC 9 ... 36 V
Model T12.10.002 (with Ex, intrinsically safe ia)	DC 9 ... 30 V
Model T12.10.006 (with Ex-protection per CSA)	DC 9 ... 30 V
Model T12.10.008 (with Ex-protection per FM)	DC 9 ... 30 V
Model T12.10.009 (with Ex, energy limited and non sparking)	DC 9 ... 36 V
Input power supply protection	reverse polarity
Ex-protection per Directive 94/9/EC ATEX Intrinsic Safety per EN 50 020	EC-Type Examination Certificate DMT 98 ATEX E 008 X
Model T12.10.002	II 1G EEx ia IIB / IIC T4 / T5 / T6
Permissible ambient temperature	-40 °C ... +85 °C with T4 -40 °C ... +75 °C with T5 -40 °C ... +60 °C with T6
Safety-related max. values for the current loop circuit (connections + und -)	$U_i = DC 30 V$ $I_i = 100 mA$ $P_i = 705 mW$ $C_i = 25 nF$ $L_i = 0.65 mH$
Safety-related max. values for the sensor circuit (connections 1 up to 4)	$U_o = DC 11,5 V$ $I_o = 31 mA$ $P_o = 87 mW$ Group II B: $C_o = 11 \mu F$ $L_o = 8.6 mH$ Group II C: $C_o = 1.5 \mu F$ $L_o = 8.6 mH$
Ex-protection, Intrinsic Safety per CSA	CSA File No. LR 105000-7
Model T12.10.006	Class I, Division 1, Groups A, B, C and D
Permissible ambient temperature	max. +85 °C with T4 max. +75 °C with T5 max. +60 °C with T6
Safety-related max. values for the current loop circuit (connections + und -)	$V_{max} = DC 30 V$ $I_{max} = 100 mA$ $P_{max} = 705 mW$ $C_i = 25 nF$ $L_i = 0.65 mH$
Safety-related max. values for the sensor circuit (connections 1 up to 4)	$V_{oc} = DC 11.5 V$ $I_{sc} = 31 mA$ $P_{max} = 87 mW$ $C_a = 0.4 \mu F$ $L_a = 8.65 mH$
Ex-protection, Intrinsic Safety per FM	Installation Drawing No. 3184731
Model T12.10.008	Class I, Division 1, Groups A, B, C and D
Permissible ambient temperature	-40 °C ... +85 °C with T4 -40 °C ... +75 °C with T5 -40 °C ... +60 °C with T6
Safety-related max. values for the current loop circuit (connections + und -)	$V_{max} = DC 30 V$ $I_{max} = 100 mA$ $P_{max} = 705 mW$ $C_i = 25 nF$ $L_i = 0.65 mH$
Safety-related max. values for the sensor circuit (connections 1 up to 4)	$V_{oc} = DC 11.5 V$ $I_{sc} = 31 mA$ $P_{max} = 87 mW$ $C_a = 1.5 \mu F$ $L_a = 8.6 mH$
Ex-protection per Directive 94/9/EC energy-limited or non sparking equipment per EN 50 021	EC-Type Examination Certificate DMT 99 E 088 X
Model T12.10.xx9	II 3G EEx nL/nA IIC T4 / T5 / T6
Permissible ambient temperature	-40 °C ... +85 °C with T4 -40 °C ... +75 °C with T5 -40 °C ... +60 °C with T6
Safety-related max. values for the current loop circuit (connections + und -)	$U_i = DC 36 V$ $C_i = 25 nF$ $L_i = 650 \mu H$
Safety-related max. values for the sensor circuit (connections 1 up to 3)	$U_o = DC 5 V$ $I_o = 0.25 mA$ $C_o = 1000 \mu F$ $L_o = 1000 mH$
Electromagnetic compatibility (EMV)	per EMC Directive 89/336/EWG DIN EN 61 326:2002
Ambient conditions	
Ambient and storage temperature	Standard range: -40 ... +85 °C Extended range (option): -50 ... +85 °C or -40 ... +105 °C ¹⁾
Climate class	Cx (-40 ... +85 °C, 5 % up to 95 % relative humidity) DIN EN 60 654-1
Maximum permissible humidity	100 % relative humidity (unlimited with isolated sensor connection wires), moisture condensation permissible DIN EN 60 068-2-30 Var. 2
Vibration	10 ... 2000 Hz 5 g DIN EN 60 068-2-6
Shock	DIN IEC 68-2-27 $g_N = 30$
Salt fog	DIN IEC 68-2-11

1) -40 ... +105 °C only without Ex-protection

Special features

Isolation voltage (input versus analogue output)	1500 VAC, 60 s
Configuration and calibration data	permanently stored in EEPROM
Testing current to monitor sensor	nom. 33 μ A during testing cycle, otherwise 0 μ A
Self-monitoring	automatic execution of initial test after connection to power supply, thereafter monitoring for internal malfunction
Warm-up time	approx. 5 Min. ¹⁾
Power consumption with U_B 24 V	max. 552 mW
Communication interface	Programming Unit PU348 (see accessories)

Case	for head mounting
Material	plastic
Ingress protection case	IP 66 IEC 529 / EN 60 529
terminal connections	IP 00 IEC 529 / EN 60 529
Cross section of terminal connections	max. 1,5 mm ² , screws captive
Weight	approx. 67 g
Dimensions	see dimensions

1) Time, after turn on, until the instrument will function within specified repeatability

Dimensions in mm

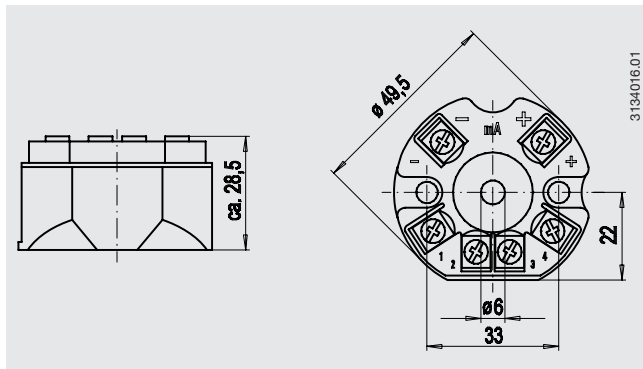

Load diagram

The permissible load is dependent upon the loop power supply voltage.

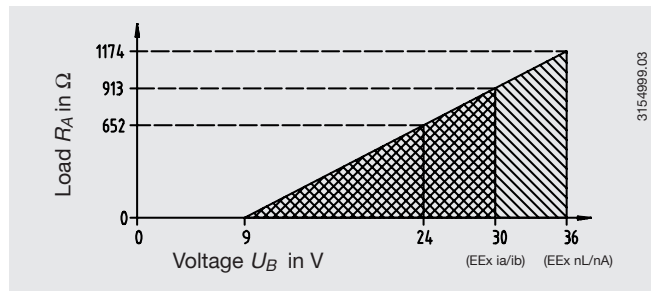

Designation of terminal connectors

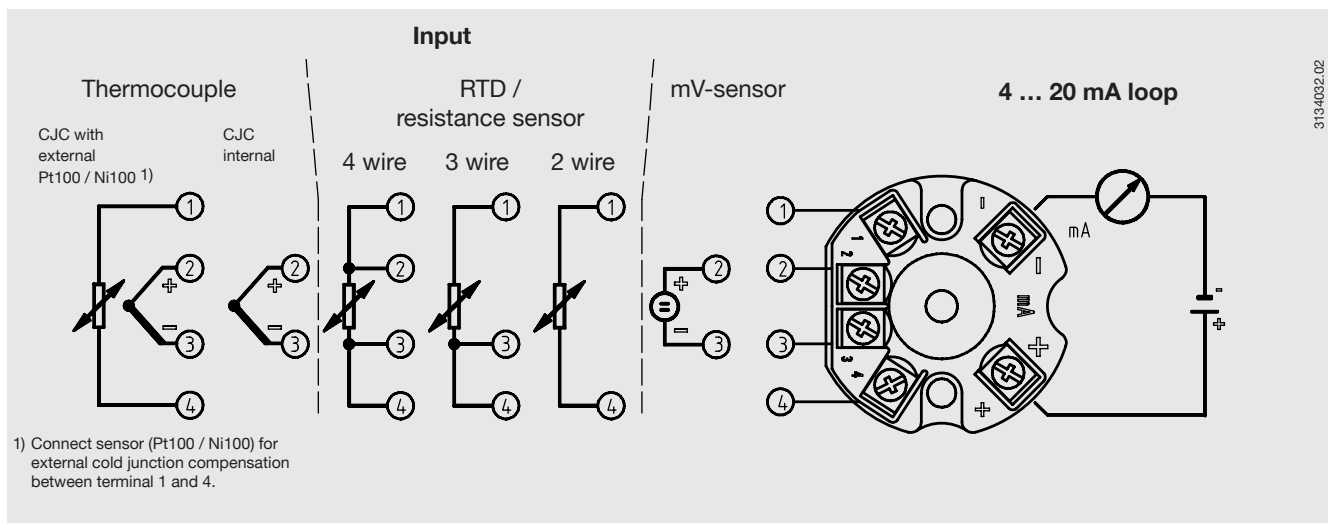

1) Connect sensor (Pt100 / Ni100) for external cold junction compensation between terminal 1 and 4.

Connection of Programming Unit PU348

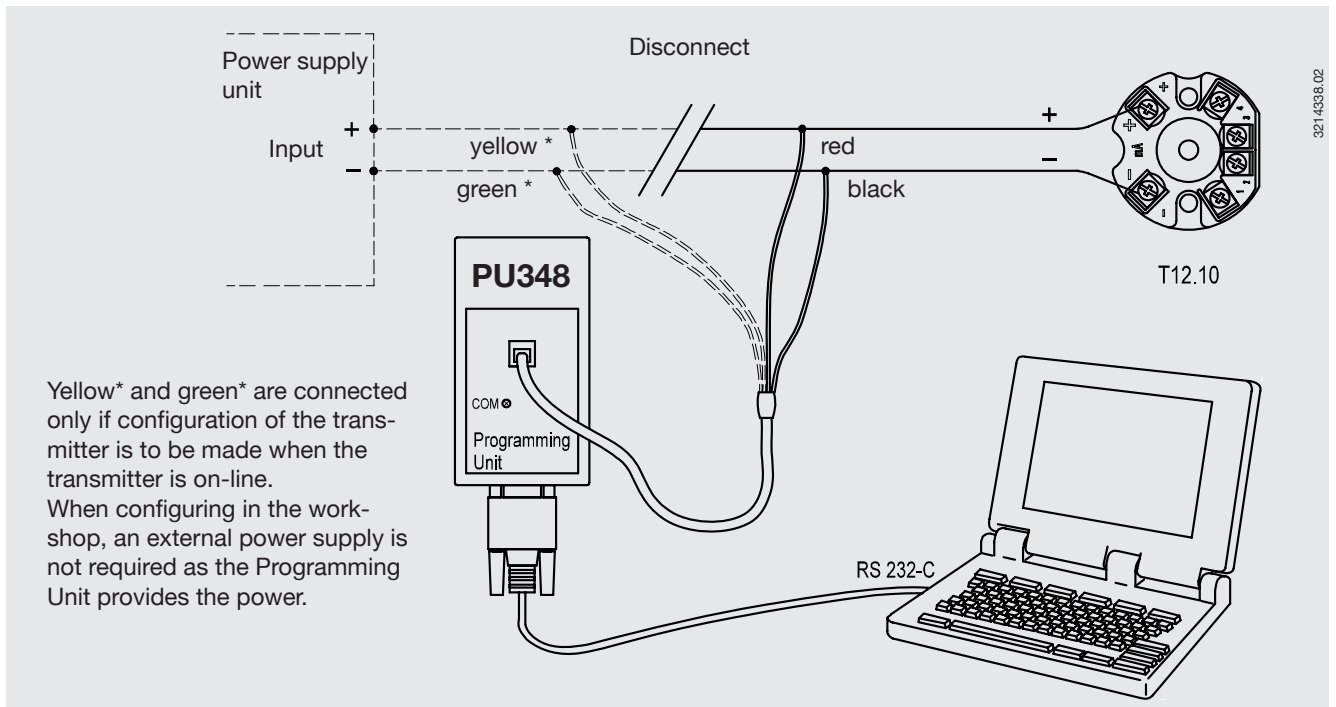

Accessories

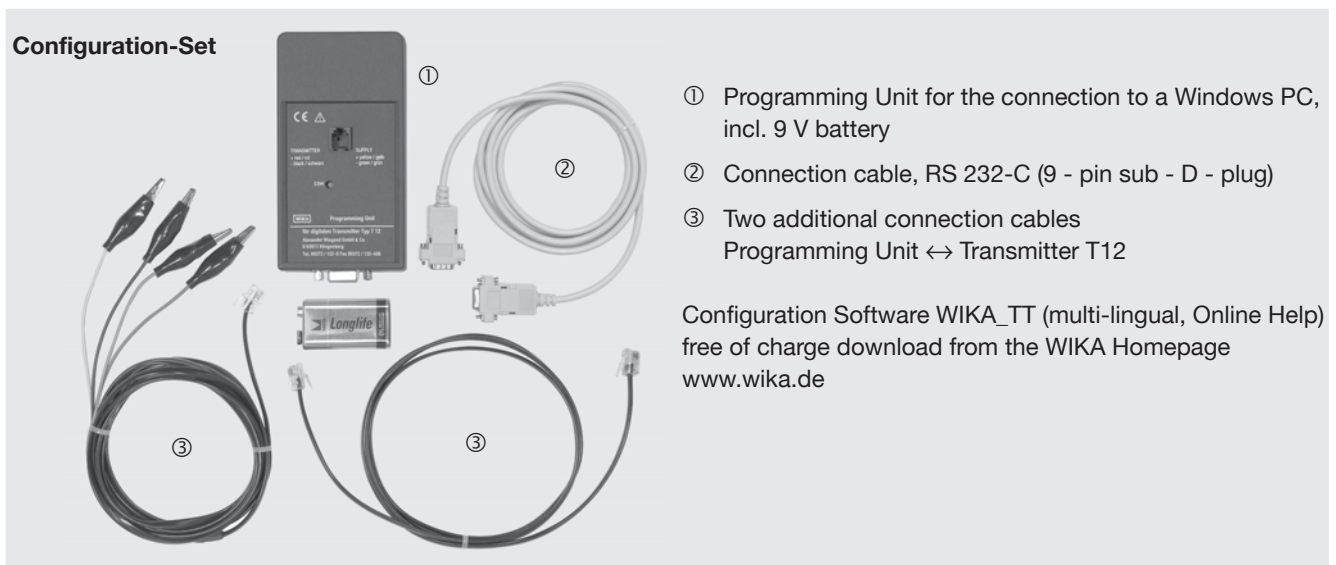

Field case

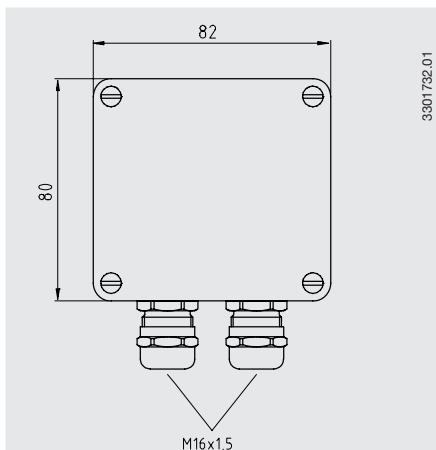

Adapter, plastic/stainless steel

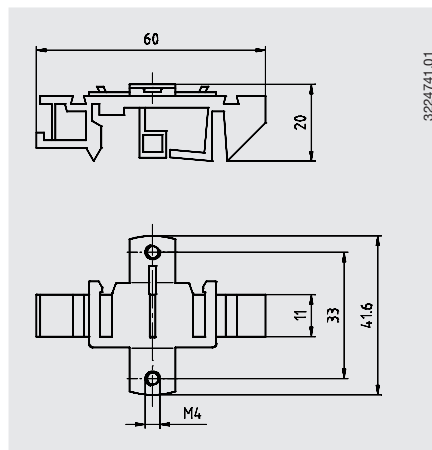

Adapter, steel tin galvanized

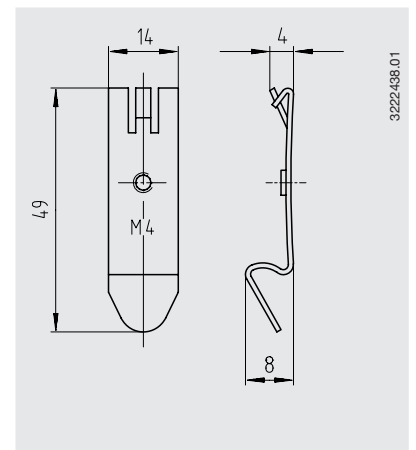

Ordering information

Field No.	Code	Features
Model		
1	<input type="text"/> T12.10	T12.10, head mounting
Explosion protection		
	<input type="text"/> 0	without
	<input type="text"/> 2	II 1G EEx ia IIC T4/T5/T6 acc. to directive 94/9/EC (ATEX)
	<input type="text"/> 6	CSA Class I, Division 1, Group A, B, C, D
	<input type="text"/> 8	FM Class I, Division 1, Group A, B, C, D
2	<input type="text"/> 9	II 3G EEx nL/nA IIC T4/T5/T6 acc. to directive 94/9/EC
Configuration		
	<input type="text"/> GK	basic configuration ¹⁾
3	<input type="text"/> KK	customer's specification ²⁾ <i>please state as additional text</i>
Admissible ambient temperature		
	<input type="text"/> S	standard -40 °C ... +85 °C
	<input type="text"/> N	extended range -50 °C ... +85 °C <i>only without explosion protection</i>
4	<input type="text"/> H	extended range -40 °C ... +105 °C <i>only without explosion protection</i>
Additional order info		
	<input type="text"/> YES	<input type="text"/> NO
5	<input type="text"/> T	<input type="text"/> Z additional text <i>Please state as clearly understandable text!</i>

Order code:

1	2	3	4	5
T12.10	- 00	<input type="text"/>	<input type="text"/>	<input type="text"/>

Additional text:

Accessories (please order separately)	Order No.
Configuration Set for T12 and T24 ³⁾	36 34842
Field case, plastic (ABS), IP 65, for mounting of a head mounting transmitter, permissible ambient temperature: -40 °C ... +80 °C, 82 x 80 x 55 mm (W x L x H), with two cable glands M16 x 1.5	33 01732
Adapter for mounting on a DIN rail, plastic/stainless steel	35 93789
Adapter for mounting on a DIN rail, steel tin galvanised	36 19851

Screenshot Configuration Software ³⁾

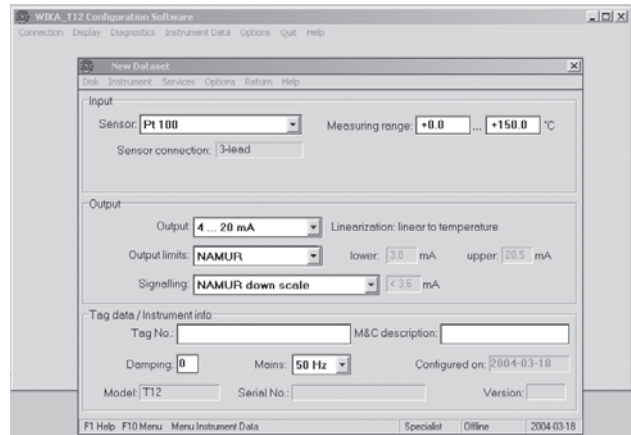

- 1) Input signal: Pt100 in 3 wire connection, Measuring range: 0 ... 150 °C, Output signal: 4 ... 20 mA, Output limits: NAMUR (lower limit: 3.8 mA upper limit: 20.5 mA), Signalling of sensor error: NAMUR down scale (3.5 mA), Damping: off
- 2) Please pay attention to the limits of measuring ranges on page 2.
- 3) Configuration software free of charge download from the WIKA Homepage www.wika.de

Specifications and dimensions given in this leaflet represent the state of engineering at the time of printing. Modifications may take place and materials specified may be replaced by others without prior notice.



WIKAL Alexander Wiegand GmbH & Co. KG
 Alexander-Wiegand-Straße 30
 63911 Klingenberg/Germany
 Phone (+49) 93 72/132-0
 Fax (+49) 93 72/132-406
 E-Mail info@wika.de
www.wika.de